

Lodestar XL Electric Chain Hoist Parts List

KEY NO.	NO. REQ'D	PART NAME	PART NUMBER
652-100	2	BRAKE HUB SNAP RING	35764
652-101	1	2ND GEAR SNAP RING	36763
652-102	1	2ND PINION SNAP RING	45766
652-103	1	MOTOR SHAFT COUPLING	52018
652-104	1	LIMIT SWITCH INPUT SHAFT	52019
652-105	1	LIFTWHEEL GEAR	52021
652-106	1	3RD REDUCTION PINION AND SHAFT	52026
652-107	1	MOTOR HOUSING ASSEMBLY (See note 1)	52631
652-108	1	BRAKE HOUSING ASSEMBLY (See note 2)	52632
652-109	1	INTERMEDIATE PLATE ASSEMBLY (See note 3)	52633
652-110	1	MAIN HOUSING ASSEMBLY (See note 4)	52630
652-111	1	LIFTWHEEL	52033
652-112	1	DRIVE SHAFT AND PINION	52036
652-113	1	CHAIN GUIDE	52041
652-114	1	CHAIN STRIPPER	52055
652-115	1	LIMIT SWITCH SHAFT ASSEMBLY	36623
652-116	1	MOUNTING BRACKET	52704
652-117	1	CONTACTOR MOUNTING PLATE	52706
652-118	2	MAIN HOUSING GASKET	52709
652-119	1	LIMIT SWITCH SPRING	52742
652-120	1	LIMIT SWITCH ASSEMBLY	52609
652-121	1	BREATHER	70726
652-122	2	DRIVE SHAFT SEAL	80401
652-123	2	DRIVE SHAFT BEARING	80402
652-124	1	2ND REDUCTION PINION BEARING - INBOARD	80403
652-125	1	2ND REDUCTION PINION BEARING - OUTBOARD	80404
652-126	1	3RD REDUCTION PINION BEARING - OUTBOARD	80408
652-127	3	CHAIN GUIDE PIN	80410
652-128	1	LIFTWHEEL BEARING - MOTOR END	80411
652-129	1	LIFTWHEEL SEAL - GEAR END	80412
652-130	1	*BRAKE COIL: (See note 5) 208-240 VOLT 380-480 VOLT 550-575 VOLT	68877 68878 68879
652-131	2	BRAKE FRICTION DISC	70652
652-132	1	LIFTWHEEL SEAL - INBOARD	80415
652-133	1	LIFTWHEEL GEAR SNAP RING	80416
652-134	1	LIMIT SWITCH INPUT SHAFT SEAL	80417
652-135	1	TRANSFORMER : 208-240/380-480 VOLT PRIMARY, 115 VOLT SECONDARY 208-240/380-480 VOLT PRIMARY, 48 VOLT SECONDARY 208-240/380-480 VOLT PRIMARY, 24 VOLT SECONDARY 550-575 VOLT PRIMARY, 115 VOLT SECONDARY	68810 70793 68811 68786
652-136	1	HOIST REVERSING CONTACTOR WITH : 115 VOLT COILS 48 VOLT COILS 24 VOLT COILS	52749 52751 52750
652-137	1	SPEED SELECTING CONTACTOR WITH : 115 VOLT COIL 48 VOLT COIL 24 VOLT COIL	70805 70806 70781

KEY NO.	NO. REQ'D	PART NAME	PART NUMBER
652-138	1	TROLLEY REVERSING CONTACTOR WITH : 115 VOLT COILS 48 VOLT COILS 24 VOLT COILS	28835 28846 28837
652-139	--	LINE CONNECTOR-SPECIFY NO REQ'D.	982158
652-140	4	MOTOR BOLT	80429
652-141	2	LIMIT SWITCH INPUT SHAFT BEARING	88437
652-142	1	BRAKE HUB	68367
652-143	1	LIFTWHEEL BEARING - GEAR END	80413
652-144	1	3RD REDUCTION PINION BEARING - INBOARD	88500
652-145	15	FRAME SCREW	987289
652-146	1	LIMIT SWITCH WORM	35756
652-147	1	LIMIT SWITCH WORM PIN	983766
652-148	1	LIMIT SWITCH GEAR PIN	983768
652-149	1	LIMIT SWITCH GEAR FOR : 6, 9, 18, 2/6, 3/9 AND 6/18 FPM 8, 12, 24, 8/2.7, 4/12 AND 8/24 FPM	52720 52713
652-150	2	FRAME PLUG (1")	989074
652-151	1	GROUND SCREW	982686
652-152	2	LIMIT SWITCH SHAFT BEARING	35751
652-153	2	LIM. SW. SHAFT BEARING SCREW	983643
652-154	1	LIMIT SWITCH GUIDE PLATE	28714
652-155	2	LIMIT SWITCH GUIDE PLATE SCREW	983614
652-156	2	FRAME PLUG (3/4")	989055
652-157	1	POWER CORD	51108
652-158	1	POWER CORD CONNECTOR	983979
652-159	1	2ND GEAR FOR : 6, 9, 18, 2/6, 3/9 AND 6/18 FPM 8, 12, 24, 2.7/8, 4/12, AND 8/24 FPM	52043 52024
652-160	1	PROTECTOR ASSEMBLY FOR : CAPACITY SPEED (TONS) (FPM) 2 18 AND 6/18 2 24 AND 8/24 3 9 AND 3/9 3 12 AND 4/12 4 9 AND 3/9 4 12 AND 4/12 5 6 AND 2/6 5 8 AND 2.7/8 6 6 AND 2/6 6 8 AND 2.7/8	52613 52614 52628 52626 52613 52614 52627 52613 52613 52614
652-161	1	ELECTRIC BRAKE COMPLETE FOR : 208-240/380-480 VOLT, SINGLE SPEED 208-240 VOLT, TWO SPEED 380-480 VOLT, TWO SPEED 550-575 VOLT, SINGLE AND TWO SPEED	52606 52606 52611 52612
652-162	1	MOTOR (ROTOR WITH BEARINGS, STATOR AND END BELL) : 208-240/380-480 VOLT, SINGLE SPEED 208-240 VOLT, TWO SPEED 380-480 VOLT, TWO SPEED 550-575 VOLT, SINGLE SPEED 550-575 VOLT, TWO SPEED	52710 52711 52712 52730 52754
652-163	-	LOAD CHAIN - SPECIFY LENGTH REQ'D	85885
652-164	1	WIRING HARNESS FOR : SINGLE SPEED TWO SPEED	51109 51110

KEY NO.	NO. REQ'D	PART NAME	PART NUMBER
652-165	2	CONTACTOR MOUNTING PLATE SCREW	983747
652-166	1	CONVERSION T.B. BRACKET	52705
652-167	2	BRACKET ATTACHING SCREW	982683
652-168	1	CONVERSION TERMINAL BOARD	28828
652-169	1	CONVERSION T.B. INSULATOR	27776
652-170	3	CONVERSION T.B. SCREW	987847
652-171	3	CONVERSION T.B. SCREW L.W.	987873
652-172	-	JUMPERS FOR SINGLE SPEED: 3-51111, 4-51112, AND 3-51113 JUMPERS REQ'D. FOR TWO SPEED: 4-51111, 6-51112, AND 2-51114 JUMPERS REQ'D.	-
652-173	3	TRANSFORMER SCREW	987859
652-174	3	TRANSFORMER SCREW L.W.	987873
652-175	1	LOWER HOOK WITH LATCH --- LATCH TYPE : 2 TON 3, 4, 5 AND 6 TON LOWER HOOK --- LATCHLOK TYPE : 2-TON 3, 4, 5 AND 6 TON 3-6 TON LOWER LATCHLOK KIT	35612 52651 36681 52625 5264
652-176	1	HALF LINK	52017
652-177	2	HOOK BLOCK : 2 TON 3 AND 4 TON 5 AND 6 TON	52025 52049 52056
652-178	1	CHAIN PLATE : 2 TON 3 AND 4 TON	52046 52048
652-179	-	HOOK BLOCK SCREW : 2 TON - 4 REQ'D. 3 AND 4 TON - 4 REQ'D. 5 AND 6 TON - 2 REQ'D.	982369 80423 80423
652-180	2	CHAIN PLATE OR IDLER HOUSING SCREW	987288
652-181	1	BRAKE END COVER	52028
652-182	1	MOTOR END COVER	52031
652-183	1	IDENTIFICATION PLATE	70728
652-184	4	BRAKE END COVER SCREW	80409
652-185	4	I.D. PLATE DRIVE SCREW	988271
652-186	2	WARNING LABEL, ELECTRICAL	24842
652-187	1	LIFTWHEEL GEAR BEARING	80414
652-188	1	2ND REDUCTION PINION FOR : 6, 9, 18, 2/6, 3/9 AND 6/18 FPM 8, 12, 24, 2.7/8, 4/12 AND 8/24 FPM	52044 52023
652-189	1	CAPACITY LABEL FOR : 2 TON 3 TON 4 TON 5 TON 6 TON	52714 52724 52716 52726 52728
652-190	1	WARNING LABEL FOR : 2 TON 3 TON 4 TON 5 TON 6 TON	52715 52725 52717 52727 52729

KEY NO.	NO. REQ'D	PART NAME	PART NUMBER
652-191	1	COIL RETAINER STRAP	35704
652-192	1	BRAKE BASE PLATE	52607
652-193	1	BRAKE FIELD PLATE	59634
652-194	3	BRAKE SPRING	68818
652-195	1	BRAKE INTERMEDIATE PLATE	68820
652-196	1	BRAKE ARMATURE	70657
652-197	3	BRAKE NUT	982448
652-198	4	MOTOR COVER SCREW	80409
652-199	2	SPEED SELECTOR SCREW	982706
652-200	1	HOOK NUT OR COLLAR FOR : 2 TON 3, 4, 5, AND 6 TON	35369 52047
652-201	1	HOOK NUT OR COLLAR PIN FOR : 2 TON 3, 4, 5, AND 6 TON	45946 80418
652-202	1	LOWER HOOK THRUST BEARING FOR : 2 TON 3, 4, 5 AND 6 TON	88505 80421
652-203	1	SHEAVE WHEEL	52050
652-204	1	DEAD END BLOCK	52051
652-205	1	DEAD END PIN	52057
652-206	2	SHEAVE WHEEL BEARING	80422
652-207	1	DEAD END BOLT (3, 4, 5 AND 6 TON ONLY)	80424
652-208	2	HOOK BLOCK CAPACITY LABEL FOR : 3 TON 4 TON 5 TON 6 TON	52738 52739 52740 52741
652-209	4	CAPACITY LABEL DRIVE SCREW	988271
652-210	1	DEAD END PLATE	52052
652-211	1	IDLER WHEEL HOUSING	52053
652-212	1	IDLER WHEEL	52054
652-213	1	ANCHOR PIN	52058
652-214	2	IDLER WHEEL BEARING	80425
652-215	4	DEAD END PLATE SCREW	987208
652-216	1	LATCH KIT FOR : 2 TON 3, 4, 5 AND 6 TON	45663 52707
652-217	1	SUSPENSION ADAPTER FOR : 2 TON 3, 4, 5 AND 6 TON	52022 52035
652-218	1	UPPER HOOK NUT FOR : 2 TON 3, 4, 5 AND 6 TON	52045 52047
652-219	1	COUNTERWEIGHT	52061
652-220	1	UPPER HOOK, LATCH TYPE, FOR : 2 TON 3, 4, 5 AND 6 TON UPPER HOOK, LATCHLOK TYPE FOR : 2 TON 3, 4, 5 AND 6 TON	52608 52651 52624 52625
652-221	1	HOOK NUT PIN	80418
652-222	1	ANTI-ROTATION PIN FOR : 2 TON 3, 4, 5 AND 6 TON	80419 80420
652-223	2	COUNTERWEIGHT SCREW	80428
652-224	1	SUSPENSION SCREW (2 TON ONLY)	987208

KEY NO.	NO. REQ'D	PART NAME	PART NUMBER
652-225	1	ANTI-ROTATION PLATE	52708
652-226	1	ANTI-ROTATION PLATE SCREW	982371
652-227	1	UPPER HOOK SUSPENSION, LATCH TYPE COMPLETE (SEE NOTE 6) :	
		2 TON	5254
		3, 4, 5 AND 6 TON	5255
652-228	2	LIMIT SWITCH BRACKET SCREW	982708
652-229	2	LIMIT SWITCH BRACKET SCREW L.W.	982226
652-230	1	LIMIT SWITCH BRACKET	35032
652-231	1	LIM. SW. ASSEMBLY ATTACH. SCREW	983614
652-232	1	DRAIN PLUG	989050
652-233	1	2ND REDUCTION PINION SNAP RING-- 6, 9, 18, 2/6, 3/9, AND 6/18 FPM UNITS ONLY.	45766
652-234	1	TROLLEY CONTACTOR BRACKET	52722
652-235	1	TROLLEY SPEED SELECTOR INSULATOR	52723
652-236	1	TROLLEY SPEED SELECTOR WITH:	
		115 VOLT COIL	28806
		48 VOLT/50 HERTZ COIL	28848
		24 VOLT COIL	28829
652-237	2	TRO. CONTACTOR BRACKET SCREW	25862
652-238	2	TRO. SPEED SELECTOR SCREW	25859
652-239	2	TROLLEY CONTACTOR SCREW	25866
652-240	1	TERMINAL INSULATOR	35881
652-241	--	TROLLEY CONTACTOR JUMPERS: 3-51661 JUMPER AND 1-51699 JUMPER	--
652-242	3	TROLLEY CONTACTOR TO SPEED SELECTOR JUMPER	51661

KEY NO.	NO. REQ'D	PART NAME	PART NUMBER
652-243	1	HOIST CONTACTOR TO TROLLEY CONTACTOR HARNESS	51118
652-244	4	BRAKE ATTACHING SCREW	946801
652-245	2	LODESTAR XL LABEL	52760
652-246	1	CONTROL CORD ATTACHING SCREW	982717
652-247	1	CONTROL CORD ATTACH. SCREW L. W.	982226
652-248	1	CONTROL CORD ATTACH. SCREW WASHER	927835
652-249	1	WARNING TAG	81704
652-250	1	CONTROL CORD ASSEMBLY FOR: SINGLE SPEED HOIST WITH 10 FT. LIFT TWO SPEED HOIST WITH 10 FT. LIFT SINGLE OR TWO SPEED HOIST WITH 10 FT. LIFT AND MOTOR DRIVEN TROLLEY (FOR OTHER LIFTS CONTACT CM)	51400 51115 51119
652-251	2	END COVER GASKET (WEATHER PROOF UNITS ONLY)	52759
652-252	2	CONTACTOR MOUNTING SCREW	982686
652-253	1	DEAD END BLOCK SPACER	52064
652-254	1	CONV. T.B. LABEL--LONG	52721
652-255	1	TROLLEY CORD HOLE PLUG	989052
652-256	1	LOOSE END SCREW	982667
652-257	1	LOOSE END SCREW WASHER	987898
652-258	1	LOOSE END SCREW WASHER	45915
652-259	1	CONV. T.B. LABEL--SHORT	52762
652-260	1	CONTROL GROMMET O-RING	52778
652-261	1	CONTROL GROMMET	52777
652-262	1	ROTOR BEARING -OUTBOARD	83692
652-263	1	ROTOR BEARING -INBOARD	83689

Notes:

1. Includes 652-128
2. Includes 652-122, 652-123, 652-125, 652-134, and 652-141.
3. Includes 652-122, 652-123, 652-124, 652-126, 652-132, 652-141, and 652-187.
4. Includes Dowel Pins, 652-129, 652-143, and 652-144.
5. Dual Voltage (208-240/440-480, 220/380 and 220/415) units use 230 volt brake coil part number 68877.
6. If complete Latchlok Type Hook Suspension is Required, Contact CM.

Part Number for Packaged Lubricants Used in the Lodestar XL Electric Chain Hoists (Refer to page 14 for Lubrication Instructions)		
Lubricant Usage	Type of Lubricant	Part Numbers and Packaged Quantity of Lubricants
Hoist Gears	Grease Oils (Amoco 85W-140)	52776 for 1 gal. can
Splines	*Grease	EP Type Grease-obtain locally
Load Chain	Oil	28608 for 1 pint Can 28619 for 1 Gal. Can
Limit Switch Shaft Threads	*Oil	"3 in 1" or Light Machine Oil-Obtain Locally
Lower Hook Thrust Bearing	*Oil	Heavy Machine Oil Obtain Locally
Trolley Trackwheel bearings and gears	Grease (Novatex #2)	28632 for 4 lb. Can 28610 for 1lb. Can
Trolley Gears	Grease (Novatex #1)	28613 for 4lb. can 28612 for 1lb. can

*These lubricants are not furnished by CM in Packaged Quantities.

When ordering lubricants, specify the type of lubricant, part number and packaged quantity required.

Touch-up Paints for Lodestar XL Electric Chain Hoists order: (1) case (12-12 oz. Aerosol Cans) of Orange Touch-up paint Part Number 84190.

Touch-up paint is only available in case quantities.

NOTE: When painting Hoists or Trolley, also order warning labels, identification labels, etc. that may be coated during painting.

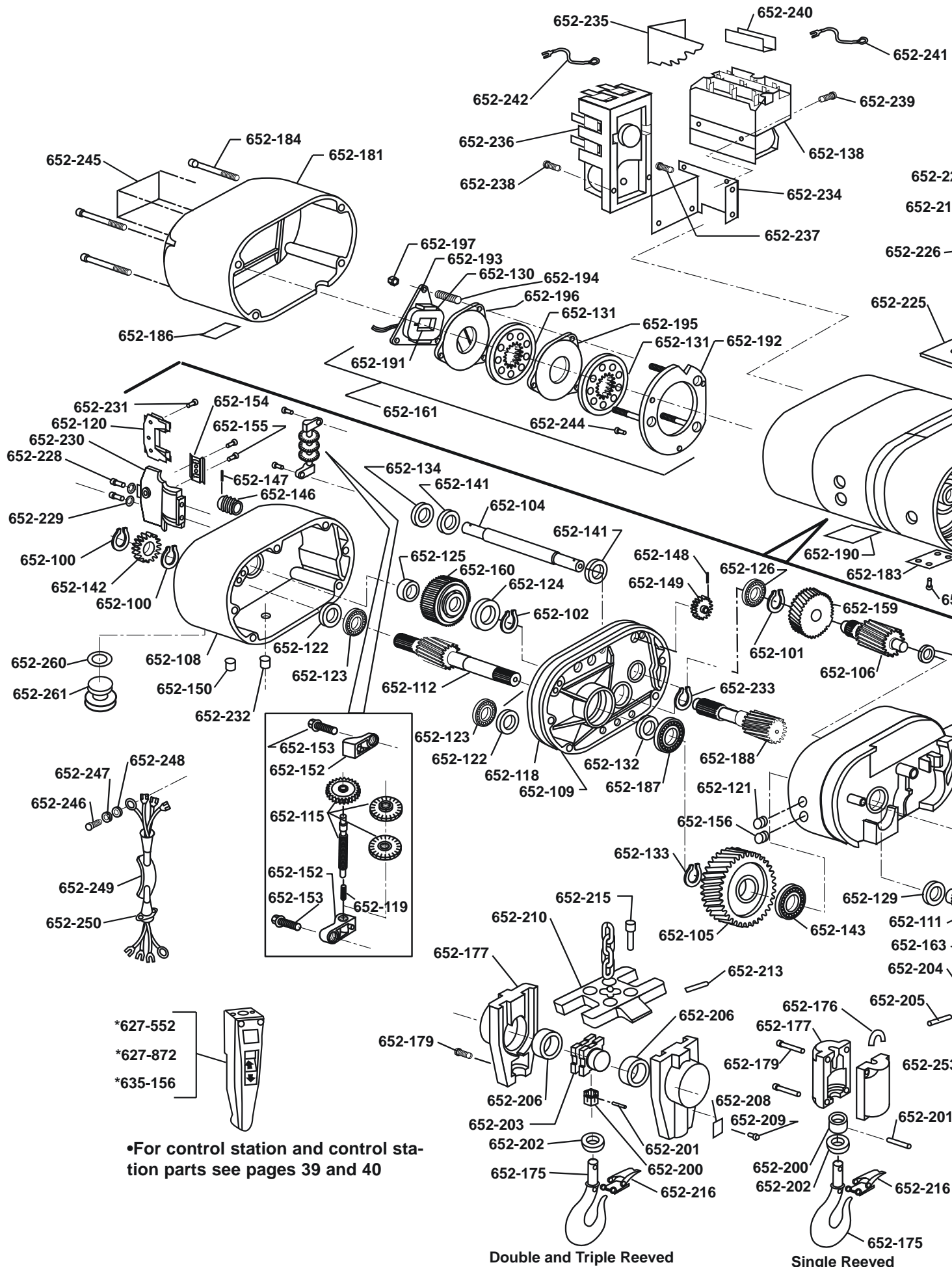

•For control station and control station parts see pages 39 and 40

Double and Triple Reeved

Single Reeved

*SEE ALSO 652-219 COUNTER WEIGHT IF ORDERING HOOK SUSPENSION PARTS SEPARATELY.

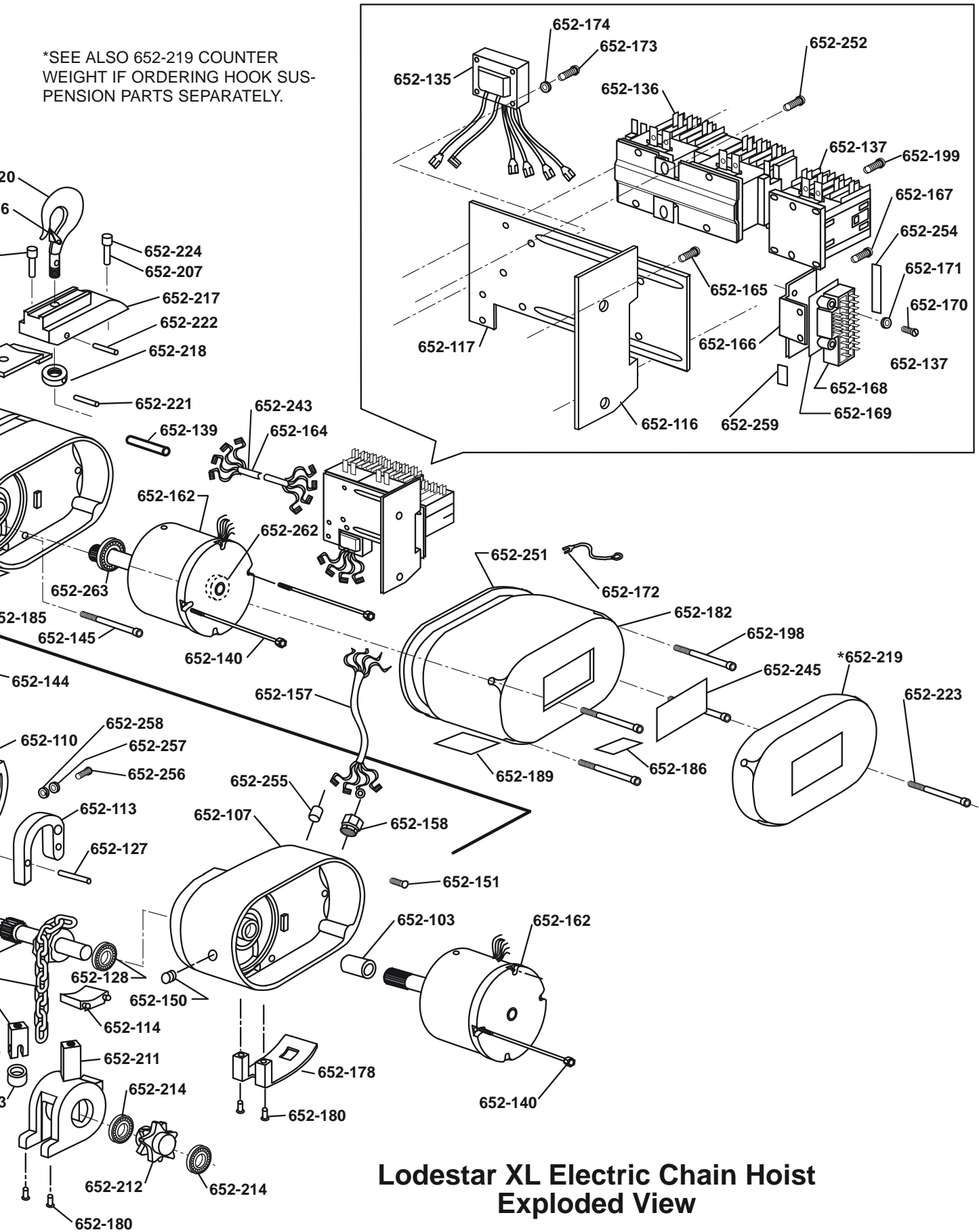

**Lodestar XL Electric Chain Hoist
Exploded View**

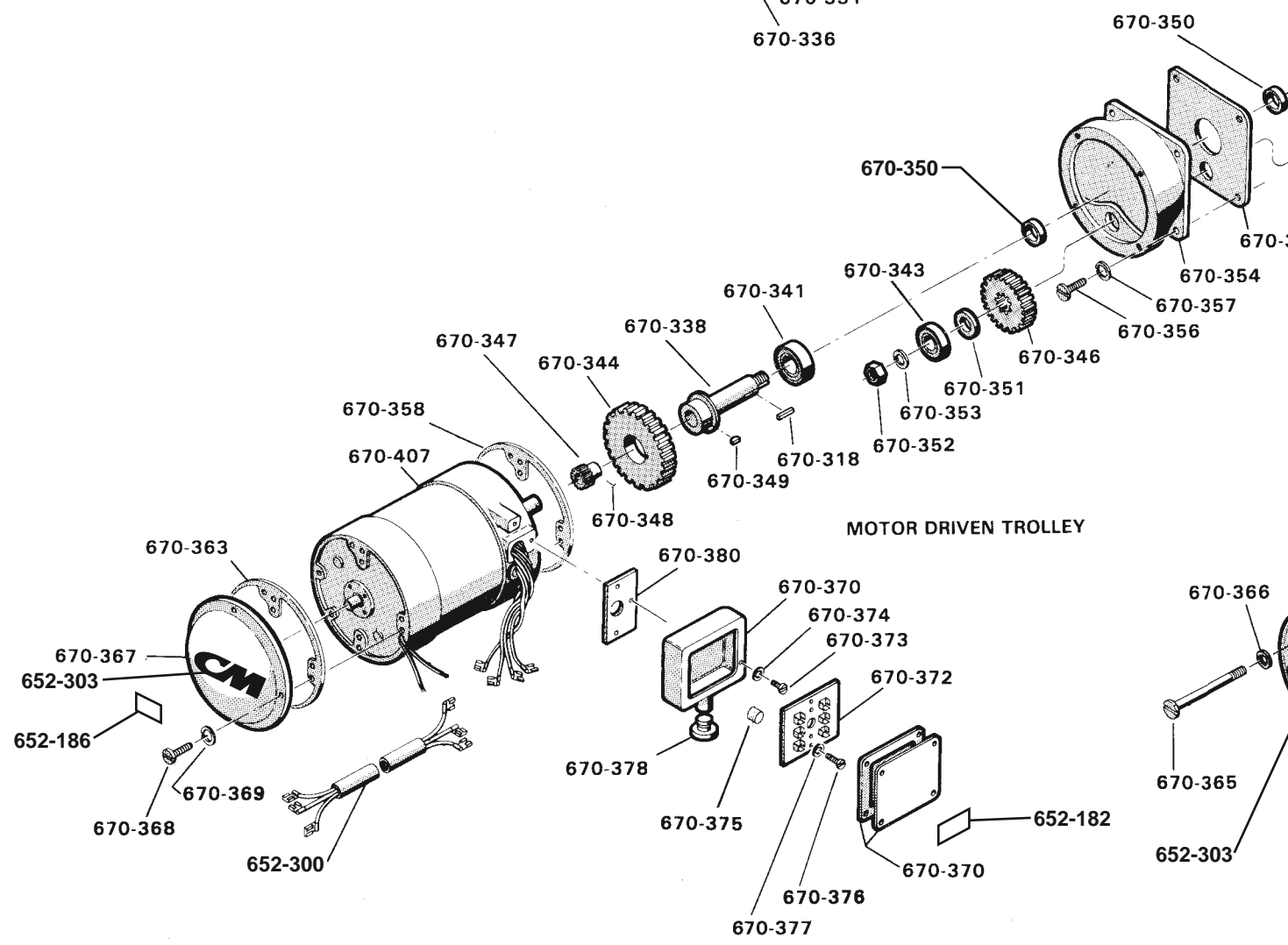
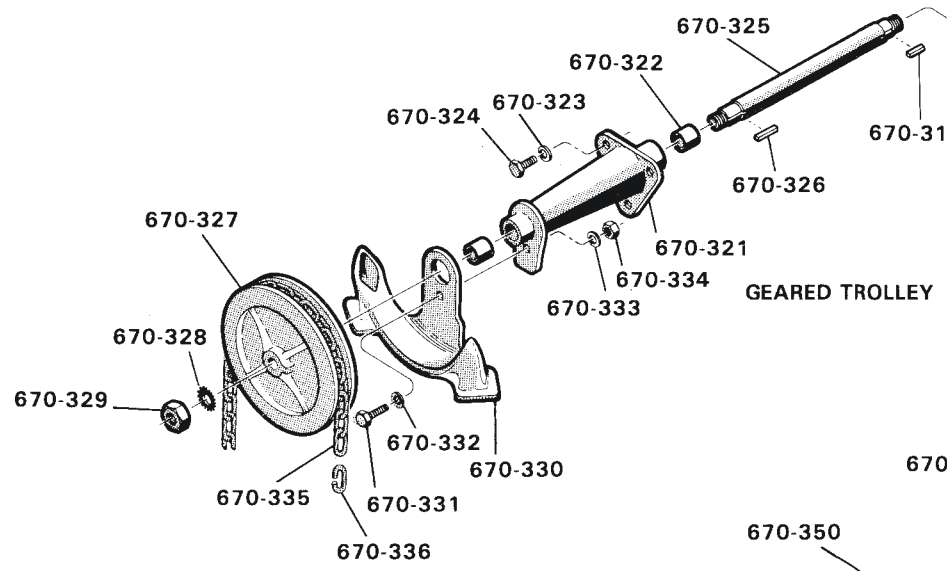

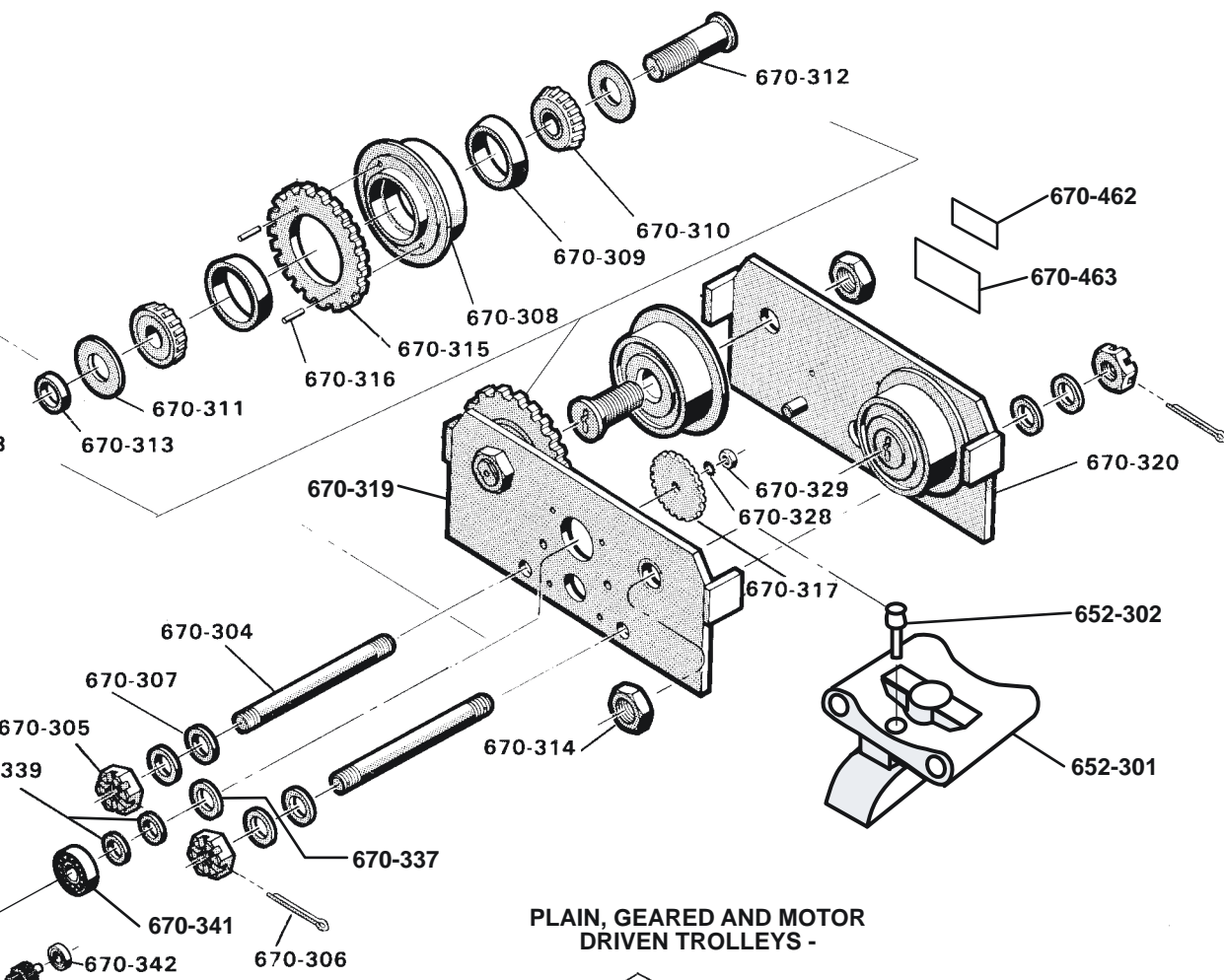

PLAIN, GEARED AND MOTOR DRIVEN TROLLEYS -

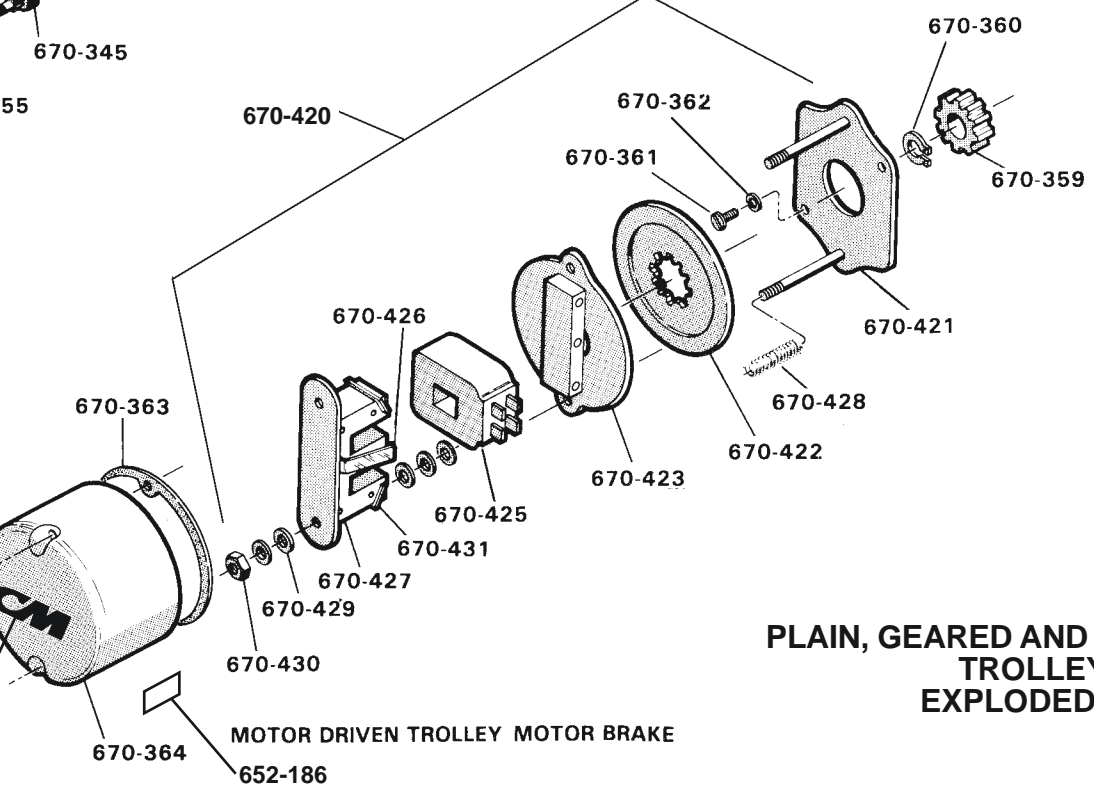

PLAIN, GEARED AND MOTOR DRIVEN TROLLEYS - EXPLODED VIEW

MOTOR DRIVEN TROLLEY MOTOR BRAKE

Plain, Geared and Motor Driven Trolleys Parts List

KEY NO.	NO. REQ'D	PART NAME	PART NUMBER	
			2 TON	3-6 TON
652-186	2	WARNING LABEL, ELECTRICAL	24842	
652-300	1	TROLLEY POWER CORD	51117	
652-301	1	HOIST SUSPENSION ADAPTER	52059	52060
652-302	1	SUSPENSION ADAPTER SCREW / DEAD END BOLT	987208	80430
652-303	1	"CM" LABEL	25779	
670-304	2	SUSPENSION BOLT FOR : 3.25" FLAT FLANGE (82.6 mm)	—	59353
		3.25" TO 5.50" FLANGE (82.6 to 139.7 mm)	58503	—
		5.51" TO 7.63" FLANGE (139.9 to 193.8 mm)	59350	—
		4.00" TO 4.63" FLANGE (101.6 to 117.6 mm)	—	59353
		5.00" TO 6.25" FLANGE (127.0 to 158.7 mm)	—	70384
		6.26" TO 7.63" FLANGE (159.0 to 193.8 mm)	—	70429
670-305	4	SUSPENSION BOLT NUT	958818	
670-306	4	SUSPENSION BOLT NUT COTTER PIN	988368	
670-307	—	SPACER WASHER - SPECIFY NO. REQ'D.	958726	
670-308	4	TRACKWHEEL WITH BEARING CUP : CROWNED TREAD	C437	C438
		FLAT TREAD	—	Contact CM
670-309	8	TRACKWHEEL BEARING CUP	88521	88556
670-310	8	TRACKWHEEL BEARING CONE	88525	88545
670-311	8	TRACKWHEEL BEARING SHIELD	68918	68917
670-312	4	TRACKWHEEL STUD	58459	70382
670-313	4	TRACKWHEEL STUD COLLAR	58484	—
670-314	4	TRACKWHEEL STUD NUT	982613	988192
670-315	2	TRACKWHEEL GEAR FOR : GEARED TROLLEY	58548	58588
		35 AND 65 FPM TROLLEYS (10.7 and 19.8 MPM)	58548	58549
		50 FPM TROLLEYS (15.2 MPM)	58548	58588
		100 FPM TROLLEY (30.4 MPM)	58548	—
		35/65 FPM TROLLEYS (10.7/ 19.8 MPM)	58548	58549
		25/50 FPM TROLLEYS (7.6/ 15.2 MPM)	58548	58588
		50/100 FPM TROLLEY(15.2/ 30.4 MPM)	58548	—
670-316	4	TRACKWHEEL GEAR PIN	983503	
670-317	1	TRACKWHEEL GEAR PINION FOR: GEARED TROLLEY	58505	58589
		35 AND 65 FPM TROLLEYS (10.7 and 19.8 MPM)	58505	58505
		50 FPM TROLLEYS (15.2 MPM)	58505	58589
		100 FPM TROLLEY (30.4 MPM)	58505	—
		35/65 FPM TROLLEYS (10.7/ 19.8 MPM)	58505	58505
		25/50 FPM TROLLEYS (7.6/ 15.2 MPM)	58487	58589
		50/100 FPM TROLLEYS (15.2/ 30.4 MPM)	58505	—

KEY NO.	NO. REQ'D	PART NAME	PART NUMBER	
			2 TON	3-6 TON
670-318	1	TRACKWHEEL PINION KEY	85546	
670-319	1	GEARED SIDE FRAME FOR : 3.25" FLAT FLANGE (82.6 mm)	—	58191
		3.25" TO 5.50" FLANGE (82.6 to 139.7 mm)	59615	—
		5.51" TO 7.63" FLANGE (139.9 to 193.8 mm)	58618	—
		4.00" TO 4.63" FLANGE (101.6 to 117.6 mm)	—	58622
		5.00" TO 6.25" FLANGE (127.0 to 158.7 mm)	—	70683
		6.26" TO 7.63" FLANGE (159.0 to 193.8 mm)	—	57631
670-320	2 REQ'D. FOR PLAIN TROLLEYS 1 REQ'D. FOR GEARED AND MOTOR DRIVEN TROLLEYS	PLAIN SIDE FRAME FOR: 3.25" FLAT FLANGE (82.6 mm)	—	58190
		3.25" TO 5.50" FLANGE (82.6 to 139.7 mm)	59614	—
		5.51" TO 7.63" FLANGE (139.9 to 193.8 mm)	58617	—
		4.00" TO 4.63" FLANGE (101.6 to 117.6 mm)	—	58621
		5.00" TO 6.25" FLANGE (127.0 to 158.7 mm)	—	70682
		6.26" TO 7.63" FLANGE (159.0 to 193.8 mm)	—	57630
670-321	1	HANDWHEEL BRACKET WITH BUSHINGS	59616	
670-322	2	HANDWHEEL BUSHING	58727	
670-323	3	HANDWHEEL BRACKET SCREW L.W.	945853	
670-324	3	HANDWHEEL BRACKET SCREW	987061	
670-325	1	HANDWHEEL SHAFT	58504	
670-326	1	HANDWHEEL KEY	59967	
670-327	1	HANDWHEEL	33143	
670-328	1 OR 2	TRACKWHEEL PINION OR HANDWHEEL SHAFT NUT L.W.	986270	
670-329	1 OR 2	TRACKWHEEL PINION OR HANDWHEEL SHAFT NUT	988095	
670-330	1	HANDCHAIN GUIDE	58152	
670-331	1	CHAIN GUIDE SCREW	987065	
670-332	1	CHAIN GUIDE SCREW WASHER	986224	
670-333	1	CHAIN GUIDE SCREW L.W.	945853	
670-334	1	CHAIN GUIDE SCREW NUT	945822	
670-335	—	HAND CHAIN - SPECIFY LENGTH REQ'D.	619022	
670-336	1	HAND CHAIN CONNECTING LINK	945491	
670-337	—	TRACKWHEEL PINION SPACER WASHER-SPECIFY NO. REQ'D.	987963	
670-338		TRACKWHEEL PINION SHAFT	58450	
670-339	1 or 2	TRACKWHEEL PINION SPACER -- SPECIFY NO. REQ'D.	58456	
670-341	2	PINION SHAFT BEARING	88438	
670-342	1	INTERMEDIATE SHAFT BEARING -- SIDE FRAME END	88437	
670-343	1	INTERMEDIATE SHAFT BEARING --MOTOR END	88436	
670-344	1	DRIVEN GEAR	58451	
670-345	1	INTERMEDIATE PINION	58452	

KEY NO.	NO. REQ'D	PART NAME	PART NUMBER	
			2 TON	3-6 TON
670-346	1	INTERMEDIATE GEAR FOR :		
		35 AND 65 FPM TROLLEYS (10.7 and 19.8 MPM)	58453	58453
		50 FPM TROLLEYS (15.2 MPM)	58407	58453
		100 FPM TROLLEY (30.4 MPM)	58407	—
		35/65 FPM TROLLEYS (10.7/ 19.8 MPM)	58453	58453
		25/50 FPM TROLLEYS (7.6/ 15.2 MPM)	58453	58453
		50/100 FPM TROLLEY (15.2/ 30.4 MPM)	58453	—
670-347	1	MOTOR PINION FOR :		
		35 AND 65 FPM TROLLEYS (10.7 and 19.8 MPM)	54356	54356
		50 FPM TROLLEYS (15.2 MPM)	58406	54356
		100 FPM TROLLEYS (30.4 MPM)	58406	—
		35/65 FPM TROLLEYS (10.7/ 19.8 MPM)	54356	54356
		25/50 FPM TROLLEYS (7.6/ 15.2 MPM)	54356	54356
		50/100 FPM TROLLEYS (15.2/ 30.4 MPM)	54356	—
670-348	1	MOTOR PINION PIN	988263	
670-349	1	DRIVEN GEAR KEY	989096	
670-350	2	PINION BEARING SPACER	58456	
670-351	1	INTERMEDIATE BEARING SPACER	58728	
670-352	1	INTERMEDIATE PINION NUT	988146	
670-353	1	INTERMEDIATE PINION NUT L.W.	986266	
670-354	1	GEAR HOUSING	70064	
670-355	1	GEAR HOUSING GASKET	58729	
670-356	4	GEAR HOUSING SCREW	987019	
670-357	4	GEAR HOUSING SCREW L.W.	945851	
670-358	1	MOTOR END BELL GASKET -	58730	
670-359	1	BRAKE HUB	59363	
670-360	1	BRAKE HUB SNAP RING	27766	
670-361	2	BRAKE ATTACHING SCREW	982708	
670-362	2	BRAKE ATTACHING SCREW L.W.	982226	
670-363	2	MOTOR COVER GASKET - WEATHERPROOF UNITS ONLY	68756	
670-364	1	BRAKE COVER	58161	
670-365	3	BRAKE COVER SCREW	968752	
670-366	3	BRAKE COVER SCREW L.W. FOR :		
		NON-WEATHERPROOF UNITS	940802	
		WEATHERPROOF UNITS	982251	
670-367	1	MOTOR END COVER	68751	
670-368	3	MOTOR END COVER SCREW	982717	
670-369	3	MOTOR END COVER SCREW L.W. FOR :		
		NON-WEATHER PROOF UNITS	982226	
		WEATHERPROOF UNITS	982251	
670-370	1	TERMINAL BOX AND COVER	58120	
670-372	1	TERMINAL BOARD	68837	
670-373	1	TERMINAL BOX SCREW	927930	

KEY NO.	NO. REQ'D	PART NAME	PART NUMBER	
			2 TON	3-6 TON
670-374	1	TERMINAL BOX SCREW L.W.		982226
670-375	2	TERMINAL BOARD SPACER		68776
670-376	2	TERMINAL BOX AND BOARD SCREW		982695
670-377	2	TERMINAL BOX AND BOARD SCREW L.W.		986290
670-378	1	POWER CORD CONNECTOR		89926
670-380	1	TERMINAL BOX GASKET		59991
670-407	1	TROLLEY MOTOR (REFER TO MOTOR NAMEPLATE) :		
		.5 HP, 600 RPM, 230/460 V.		57766
		.5 HP, 600 RPM, 575 V.		57782
		.5 HP, 1200 RPM, 230/460 V.		68916
		.5 HP, 1200 RPM, 575 V.		57771
		.25/.5 HP, 600/1200 RPM, 230 V.		57273
		.25/.5 HP, 600/1200 RPM, 460 V.		57274
		.25/.5 HP, 900/1800 RPM, 230 V.		57778
		.25/.5 HP, 900/1800 RPM, 460 V.		57779
		.25/.5 HP, 900/1800 RPM, 575 V.		57783
670-420	1	TROLLEY BRAKE (INCLUDES 670-421, 670-422, 670-423, AND 670-425 THROUGH 670-431) FOR :		59692
		230/460 V. SINGLE SPEED AND 230 V. TWO SPEED TROLLEYS		
		460 V. TWO SPEED TROLLEYS		59694
		575 V. SINGLE AND TWO SPEED TROLLEYS		59693
670-421	1	BRAKE BASE PLATE		28668
670-422	1	FRICITION DISC		27677
670-423	1	BRAKE ARMATURE		28678
670-425	1	BRAKE COIL FOR:		
		230/460V. SINGLE SPEED AND 230 V. TWO SPEED TROLLEYS		51518
		460 V. TWO SPEED TROLLEYS		51519
		575 V. SINGLE AND TWO SPEED TROLLEYS		51520
670-426	1	BRAKE COIL RETAINER STRAP		57753
670-427	1	BRAKE FIELD		28677
670-428	2	BRAKE SPRING		68750
670-429	10	BRAKE SPACER WASHER		954807
670-430	2	BRAKE STUD NUT		945840
670-431	2	SHADING COIL		54831
670-462	1	WARNING LABEL		936984
670-463	1	CAPACITY LABEL	957928	52761

Parts List			
Key No.	Part Name	Number Required	Part Number
627-552	Control Station (Items 627-553, 627-554, 627-555, 627-563, 627-565 and 627-820)	1	28630
627-551	Control Station Kit Consists of: 1-Neoprene Grommet 1-Grommet Retainer Ring 2-Grommet Retainer Ring Attaching Screw 4-Cover Attaching Screw	1	28627
627-553	Case	1	28873
627-554	Gasket	1	28876
627-555	Cover Assembly (Decal & Rocker included)	1	51477
627-563	Control Station Parts Kit Consists of: 1-Strain Cable Attaching Screw 1-Strain Cable Attaching Screw Washer 2-Switch Mounting Pin 2-Pin Retainer Screw 2-Switch Leaf Spring	1	51481
627-565	Control Station Switch Kit Consists of: 2-Switch 1-Jumper 1-Terminal 1-Screw	1	51472
627-820	Warning Label	1	24842

*Also order control Station Kit Key No. 627-551, Part No. 28627.

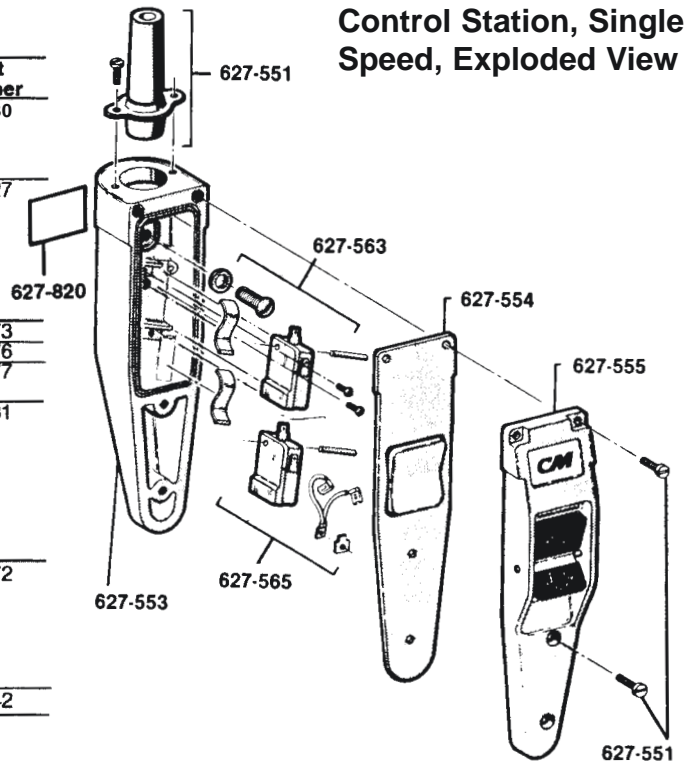

Parts List			
Key No.	Part Name	Number Required	Part Number
627-551	Control Station Kit Consists of: 1-Neoprene Grommet 1-Grommet Retainer Ring 2-Grommet Retainer Ring Attaching Screw 6-Cover Attaching Screw	1	36634
627-553	Case	1	28872
627-554	Gasket	1	28875
627-555	Cover Assembly (Decal and Rocker included)	1	51478
627-563	Control Station Parts Kit Consists of: 1-Spring 1-Strain Cable Attaching Screw 1-Strain Cable Attaching Screw Washer 2-Switch Attaching Pin 1-Sliding Cam 2-Spring End Support 3-Switch Mounting Plate & Rocker Assembly Attaching Screw 1-Rocker Assembly 1-Cam Return Spring	1	51473
627-565	Control Station Switch Kit Consists of: 3-Switch 2-Insulator 1-Jumper	1	51474
627-820	Warning Label	1	24842
627-872	Control Station (Items 627-553 thru 627-555, 627-563, 627-565 and 627-820)	1	*36693

*Also order control Station Kit
Key No. 627-551, Part No. 36634

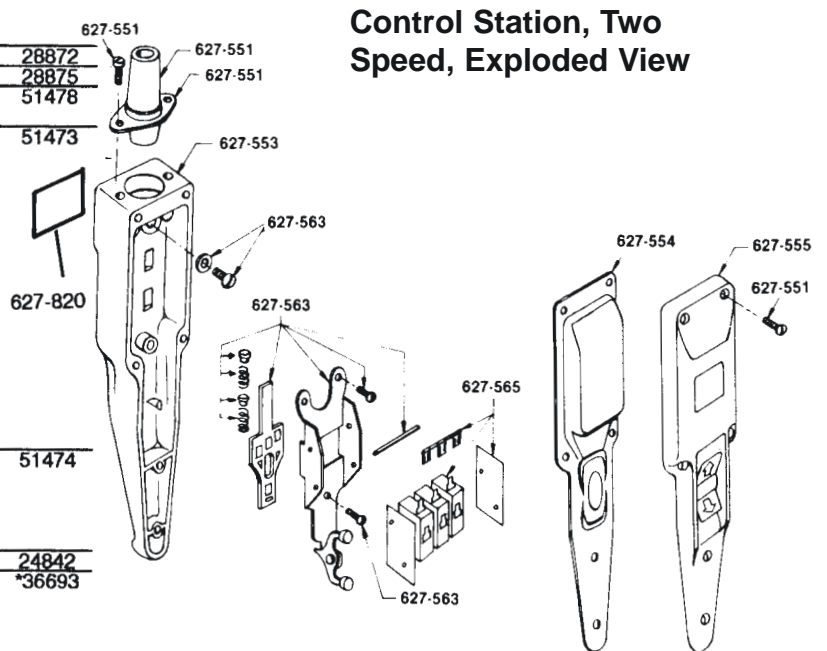

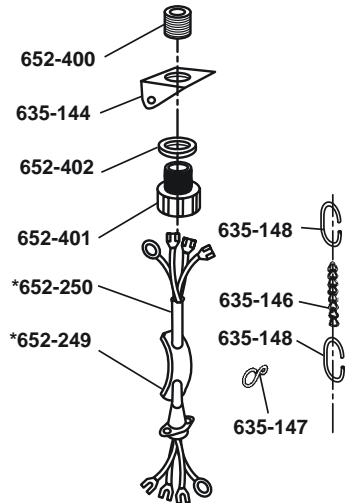
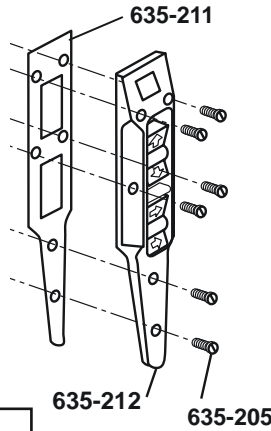
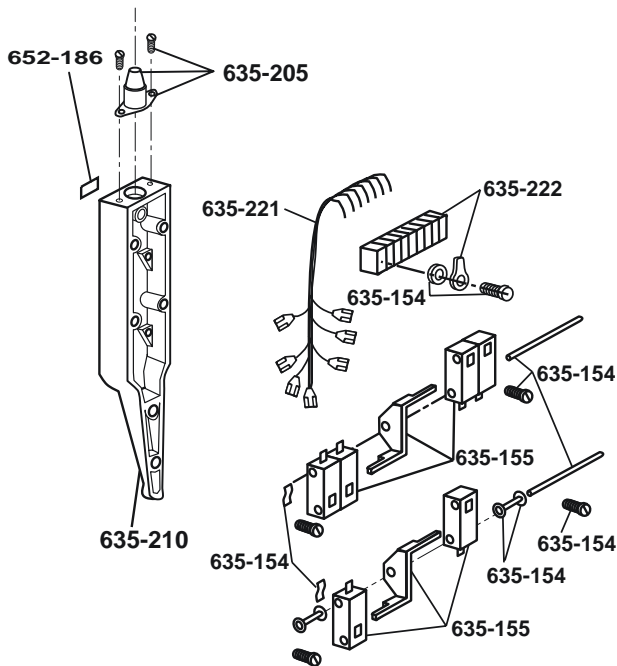

CM 4 Directional Control Station Parts List

Control Cord, Chain Strain Relief and Related Parts

* Refer to parts list on pages 30, 31
and 32 for information on these parts

Key No.	No. Req'd	Part Name	Part Number
635-144	1	Chain clip at hoist: 68704 for control cord with 8 conductors, 57817 for control cord with 10 conductors	--
635-146	--	Control station support chain (Specify length req'd)	621431
635-147	--	Cable clip-specify no. req'd	54749
635-148	--	Open link-specify no. req'd	59883
635-154	1	Control station parts kit consisting of: 1-Strain cable attach. screw 1-Terminal strip spacer 2-Switch mounting pins 4-Pin retainer screws 2-Switch spacers 2-Switch spacer washers 6-Leaf springs	71601
635-155	1	Control station switch kit Consisting of: 6-Switch 2-Interlocks	71602
635-156	1	Control station complete: *CM 4 directional (1 or 2 speed hoist with 1 speed trolley) 6 button type SPB (on-off, 1 speed hoist, 1 speed trolley) (For other control stations, contact CM.)	70620 58209 -
635-205	1	Control station kit consisting of: 1-Grommet 1-Grommet retaining ring 2-Retaining ring screws 6-Cover screws	70507
635-210	1	Case	28874
635-211	1	Gasket	28877
635-212	1	Cover assembly (cover, rockers and decal)	71604
635-221	1	Wiring harness	51546
635-222	1	Terminal strip and mounting lug kit consisting of: 1-Terminal strip 2-Mounting lug	71603
652-186	1	Warning label	24842
652-400	1	Reducer (1" to 3/4")	89946
652-401	1	Connector for: 8 Conductor cord (3/4") 10 Conductor cord (1")	983979 89382
652-402	1	Sealing Ring For: 8 Conductor cord (3/4") 10 Conductor cord (1")	983963 984901

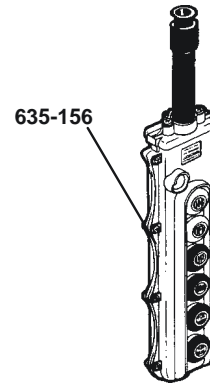

**Type SPB Control
Station-Individual
components not
available for repair**

Multifunction Control Stations

* Also order control station kit part number 70507